

# Everfit

## TRAMPOLINE

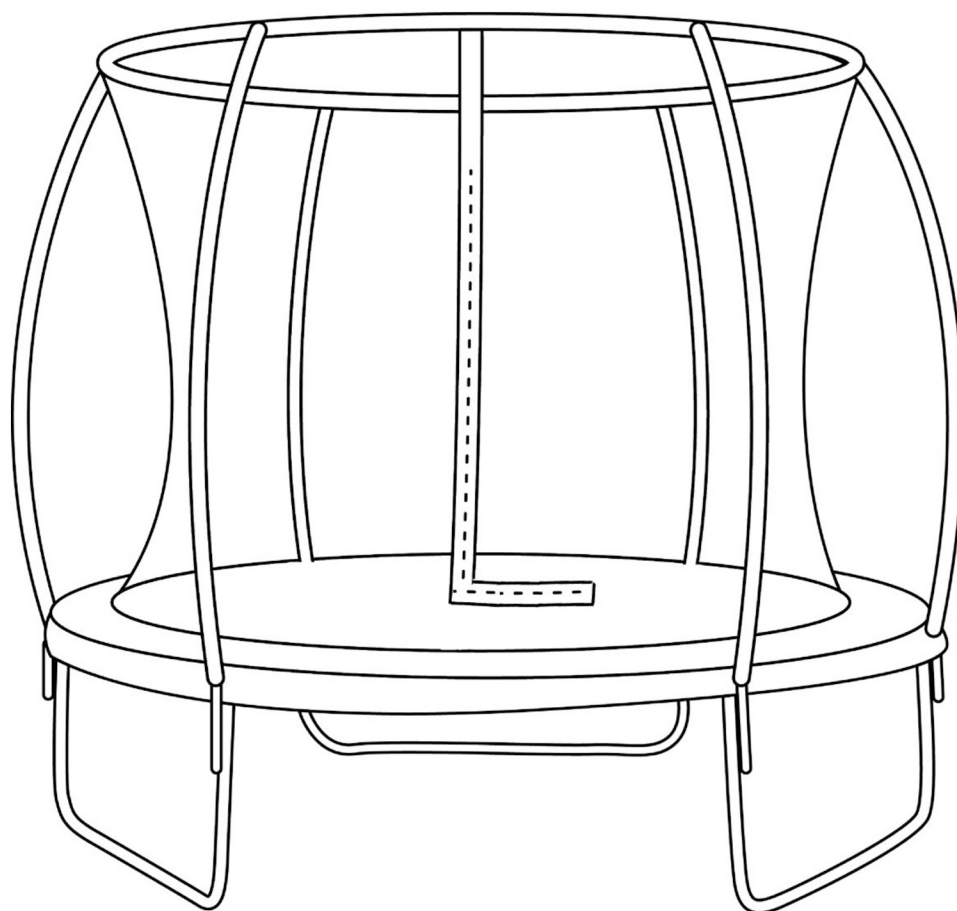

# USER MANUAL

### ATTENTION

SAFETY INFORMATION, INSTALLATION, CARE  
AND MAINTENANCE INSTRUCTIONS.

READ PRIOR TO ASSEMBLING AND USING THE TRAMPOLINE.

The assembly of this trampoline requires at least two able-bodied adults to work together.  
Assembly time may take between four and six hours.

## LOCATION REQUIREMENTS





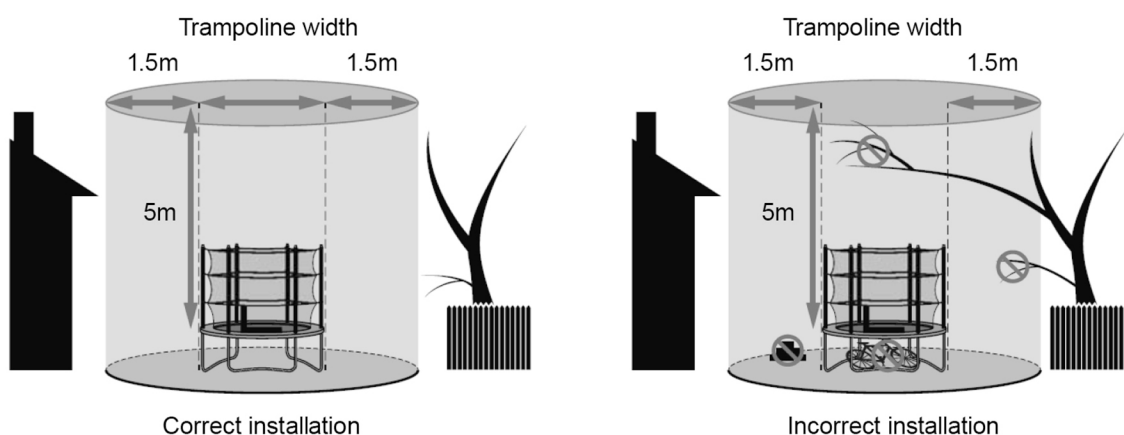



Please consider the following pointers on the location of your trampoline before starting to assemble and use the trampoline.

1. Place the trampoline on a flat and level surface with impact-accentuating properties such as grass and ensure that it is sufficiently stable to prevent it from tipping over and/or blowing away. Sandbags or pegs may be suitable anchorage devices.
2. Maintain a minimum distance of 5m overhead clearance when measured from the bed height to prevent users from inadvertently contacting overhead hazards such as electrical wires, tree limbs and clothes lines.
3. Maintain a distance of 1.5m clearance on all sides of the trampoline. This area should not include concrete, bitumen, brick or other hard surfaces as these can cause serious injuries if users fall off the trampoline.
4. Do not locate the trampoline on top of other objects or store anything underneath the trampoline bed.  
NOTE: Children have been injured while bouncing on trampolines and landing on things like garden tools, bicycles and toys.
5. Keep the area surrounding the trampoline clear. Place the trampoline away from walls, structures, fences and other play areas.
6. Place the trampoline in a well-lit area.









NOTE: It is recognised that accessories specifically designed to cover the trampoline, such as tents or sunshades, may be provided with this trampoline or sold separately. This does not eliminate the requirements for clearance above the trampoline. It is recommended that such accessories be provided with specific instructions concerning safe use.

## PACKING LIST

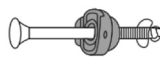
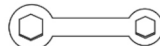
PART	DESCRIPTION	8FT	10FT	12FT	14FT	16FT
A	 Circular frame segment	6	8	8	8	12
B	 Spring padding	1	1	1	1	1
C	 Jumping mat	1	1	1	1	1
D	 Spring	48	64	72	80	108
E	 Leg extension tube	0	8	8	8	12
F	 Leg	3	4	4	4	6
G	 Leg extension tube screw	0	8	8	8	12
H	 Spring tool	1	1	1	1	1
I	 Steel T-pipe with screw	6	8	8	8	12

## PACKING LIST

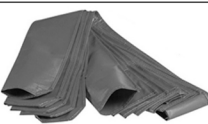
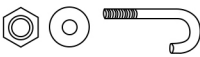
PART	DESCRIPTION	8FT	10FT	12FT	14FT	16FT
J	 Safety net	1	1	1	1	1
K	 Upper safety net support pole	6	8	8	8	12
L	 Lower safety net support pole	6	8	8	8	12
M	 Safety net support pole screw	12	16	16	16	24
N	 Wrench	1	1	1	1	1
O	 Safety net rod plastic holder	6	8	8	8	12
P	 Safety net fastening nylon rope	1	1	1	1	1
Q	 Safety net rod	6	8	10	12	12
R	 PVC sleeve	6	8	8	8	12
S	 J-screw	0	1	1	1	1

## ASSEMBLY STEPS

### Step 1

Install the circular frame segment (A) and tighten the screws on the steel T-pipe (I).

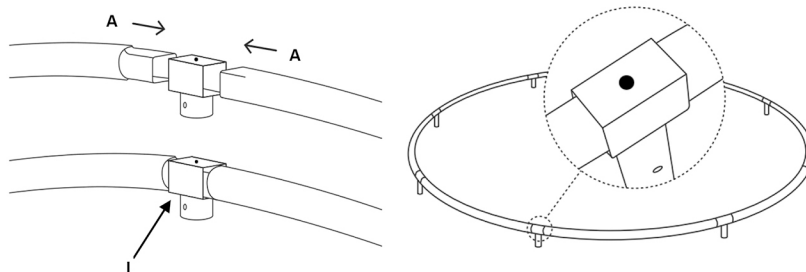

### Step 2

Install the leg (F) and leg extension tubes (E).

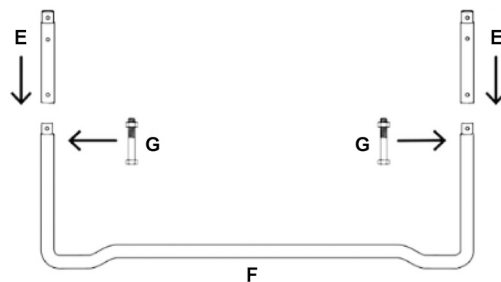

### Step 3

Complete the installation of the frame section as shown in the drawing.

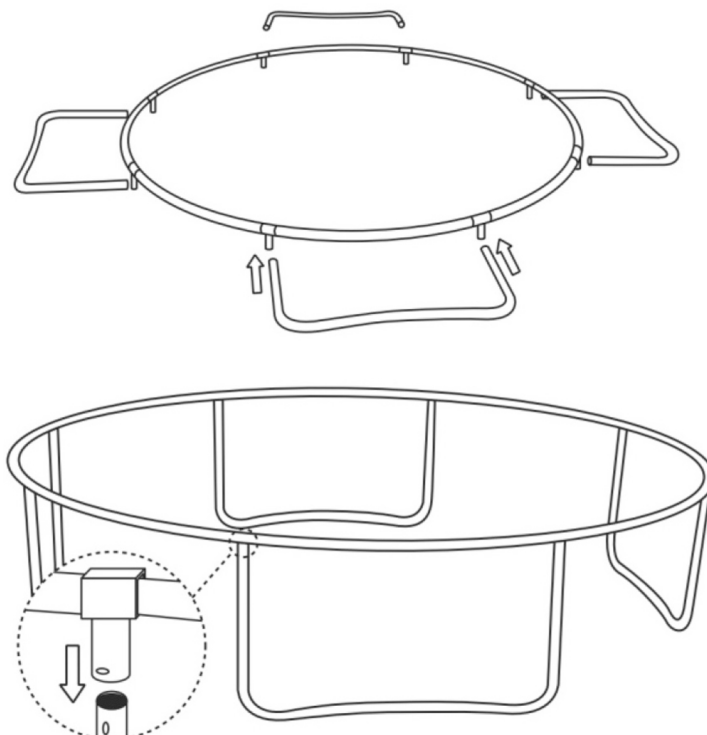

NOTE: The screws can be installed later in Step 7.

## ASSEMBLY STEPS

### Step 4

Attach the springs (D) onto the circular frame segment (A). Pay attention to the facing (A and B) of the springs when attaching them.

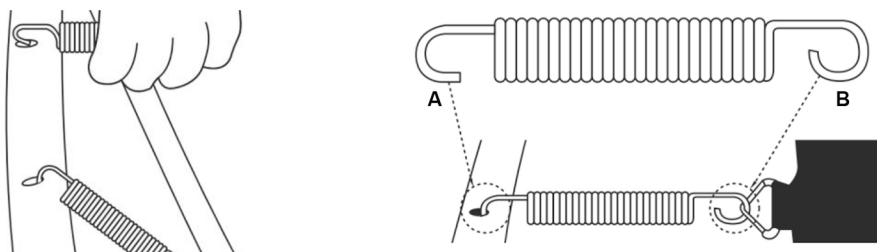

### Step 5

Install the jumping mat (C) in accordance with the steps below:

- Connect the four springs at 3-6-9-12 o'clock positions to form a diamond (A).
- Connect the springs in the middle of two points to form an 8-sided (octagon) shape (B).
- Connect the rest of the springs (C).

NOTE: The steps above must be observed in order to install the jumping mat properly. If all the springs on the same side are attached first, the hooks on the other side will be under great stress to hang the other springs.

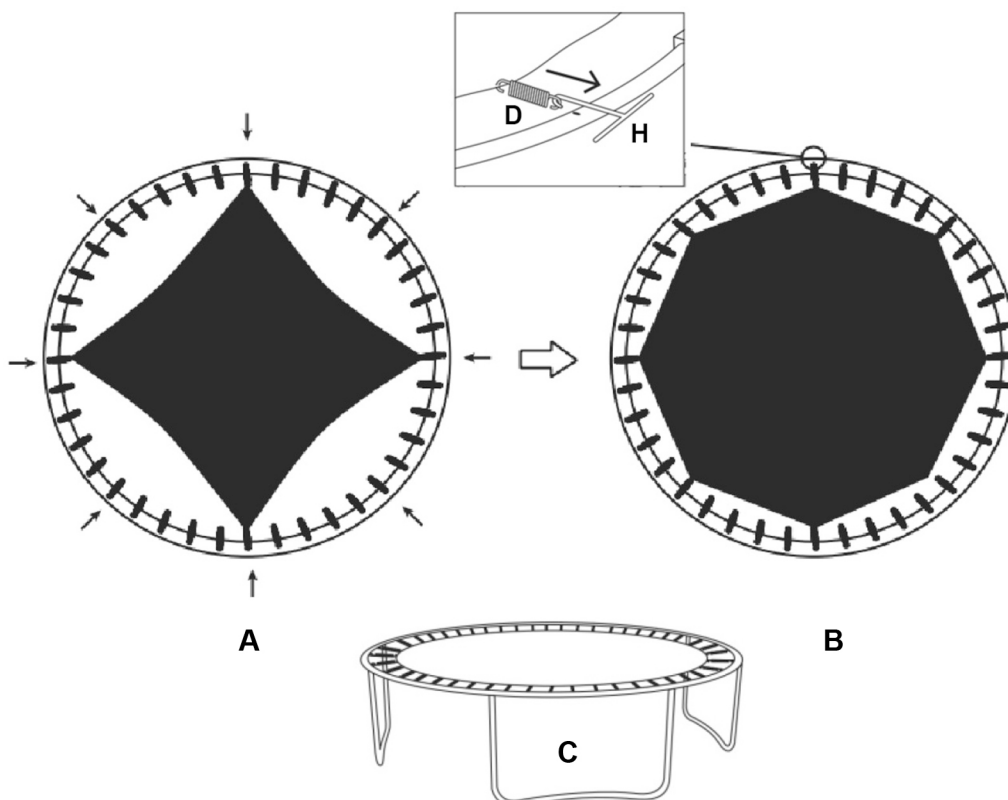

## ASSEMBLY STEPS

### Step 6

Attach the spring padding (B) by tying it to the springs as shown in the drawing.

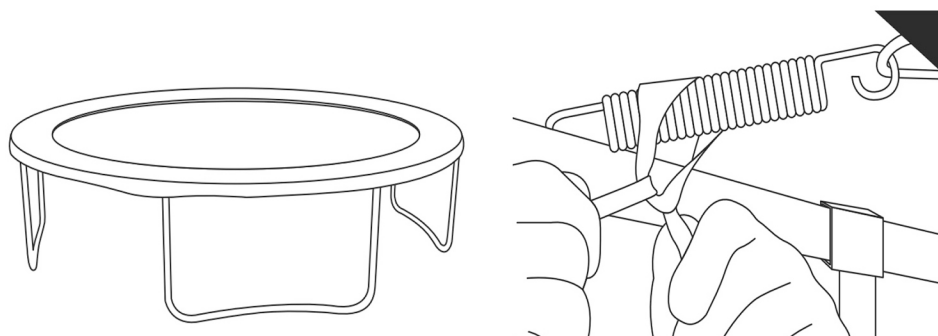

### Step 7

Attach the lower safety net support poles (L) to the circular frame segment and legs with the support screws (M) as shown in the drawing. Be careful with this step as the jumping mat can be easily scratched by metal parts. As such, the poles need to be handled gently and cannot be dragged on the jumping mat.

Connect the upper and lower safety net support poles as shown in the drawing.

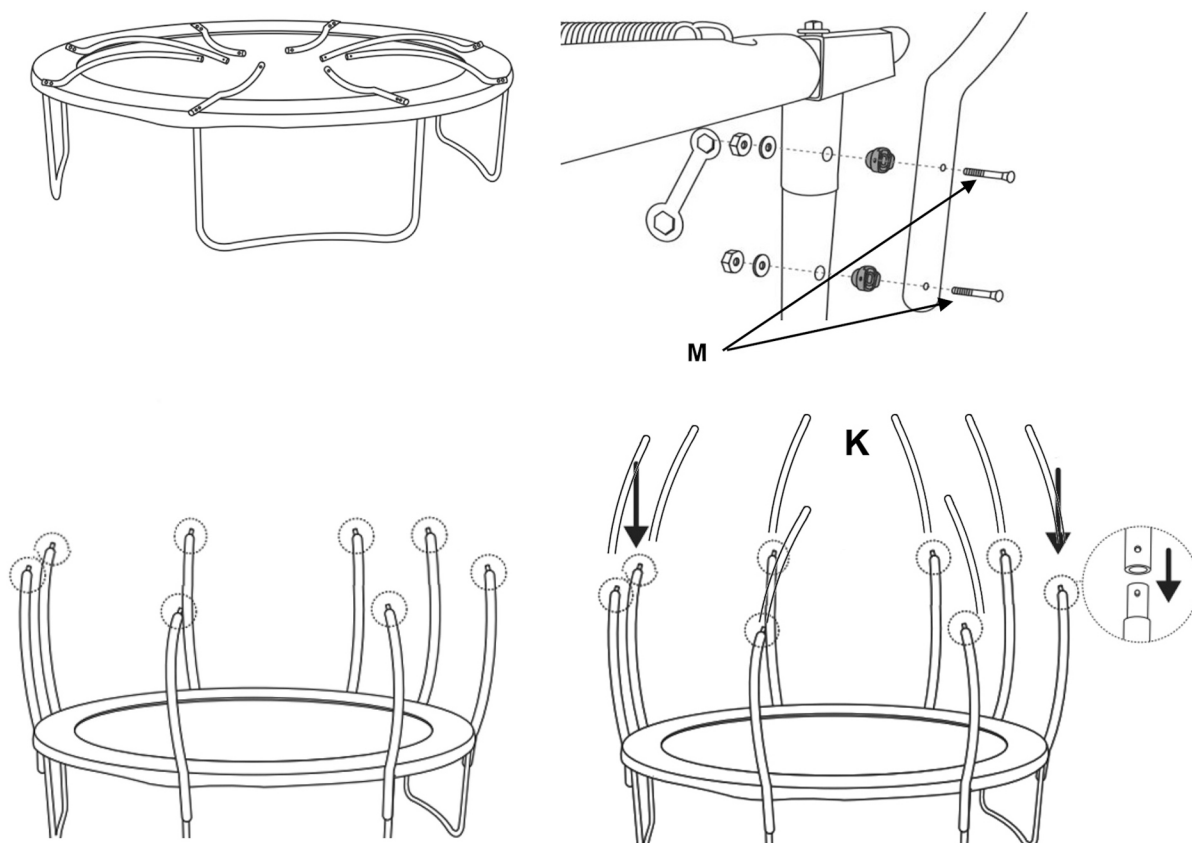

## ASSEMBLY STEPS

### Step 8

Put on PVC sleeve(R). (start with the bigger end.)

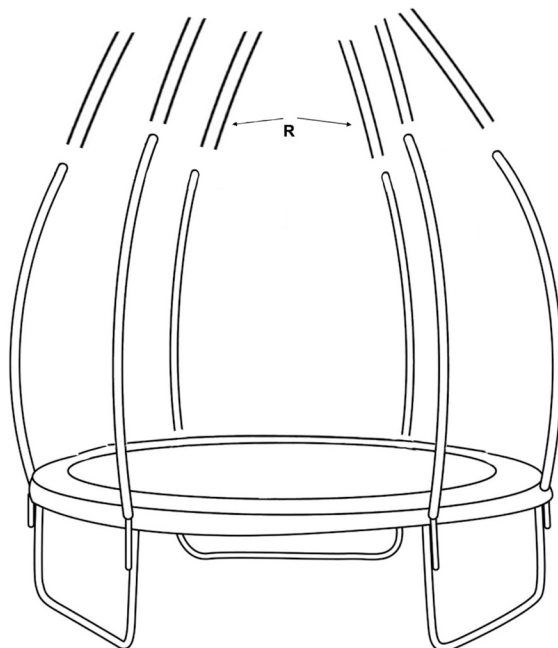

### Step 9

Insert the safety net rod (Q) into the safety net (J) sleeve as shown in the drawing.

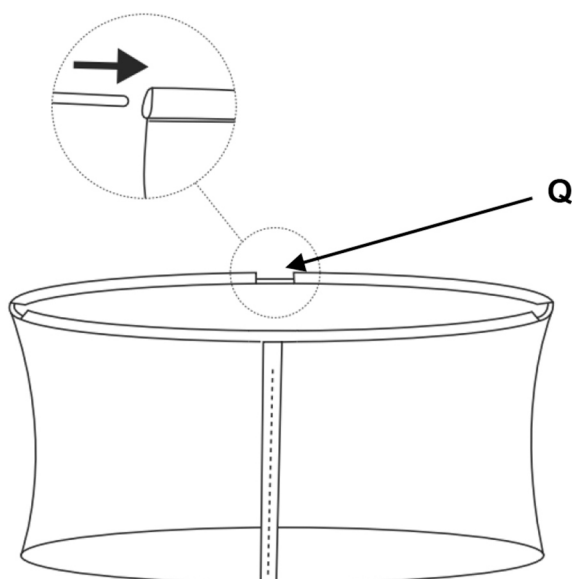



## ASSEMBLY STEPS

### Step 10

Attach the upper safety net support poles (K) to the safety net (J) via the safety net rod plastic holders (O) as shown the drawing. Ensure that the plastic holders are placed in between the safety net door zipper.

For trampolines of 10 to 16FT, there will be an extended pole to install the basketball rack. The safety net rod here is secured by J-screw (S).

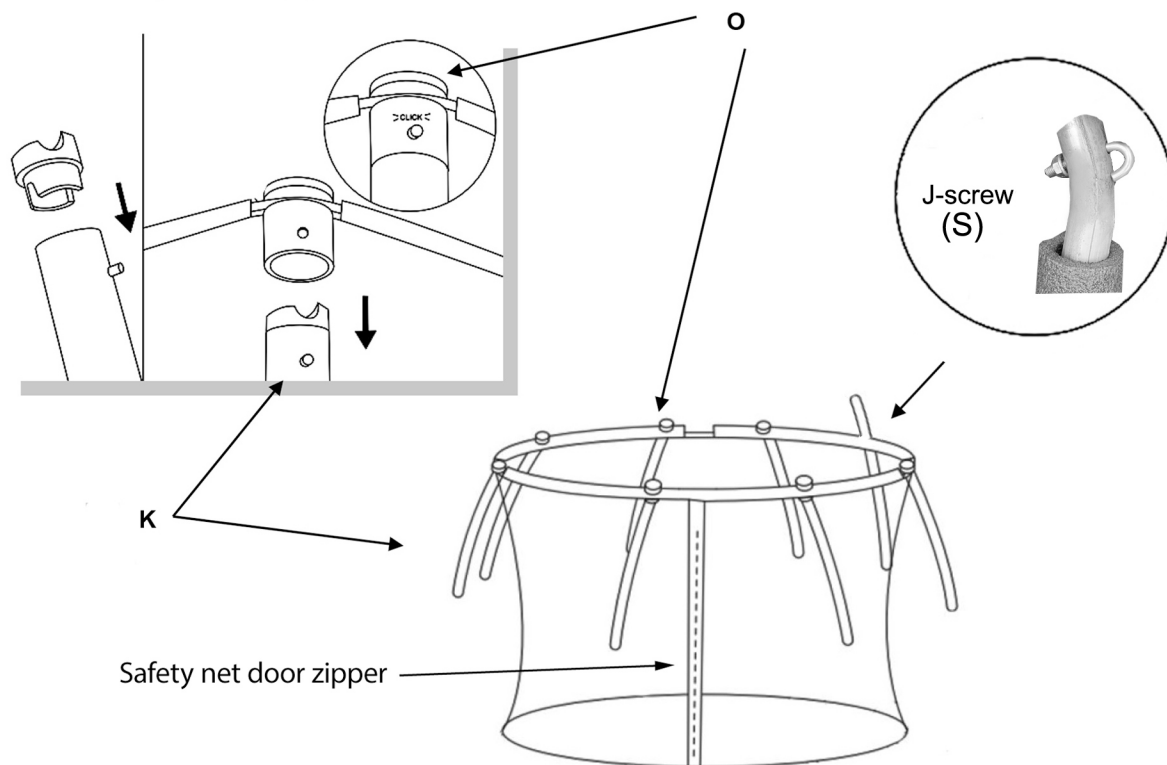

### Step 11

Attach the safety net to the springs of the jumping mat through the sleeve of the safety net as shown in the drawing. The springs may need to be released and re-hang again by use of the spring tool (H).

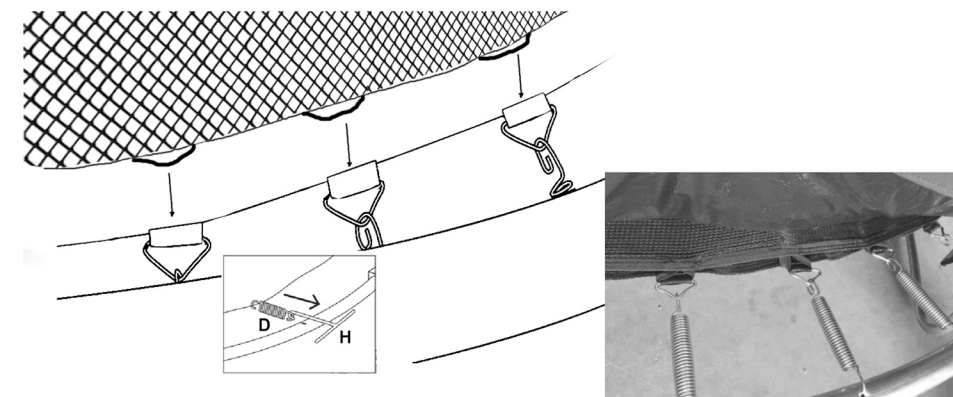

## ASSEMBLY STEPS

### Step 12

String the nylon rope through the rings of the springs to further reinforce the safety net as shown in the drawing. The assembly of the trampoline is now completed.

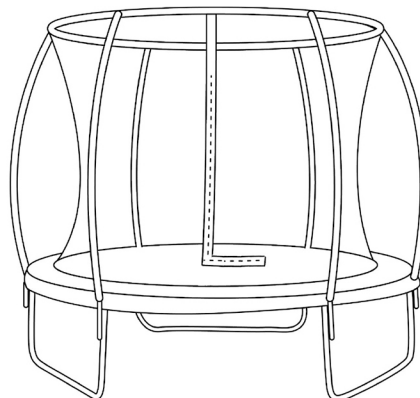
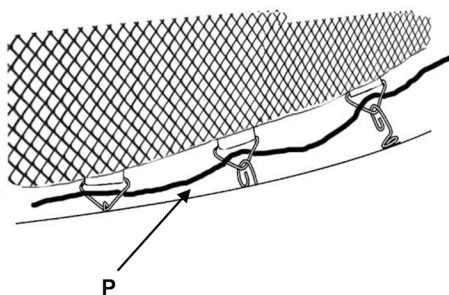

## CARE AND MAINTENANCE

Components of the trampoline are susceptible to deterioration from use and environmental conditions, such as sunlight, rain, salt and heat, to varying degrees. It is essential that you inspect the trampoline before each use and replace any worn, defective or missing part before further use. Use only parts that are recommended by the manufacturer. Take note of the potential hazards of the trampoline components as outlined in the chart below.

### POTENTIAL HAZARDS OF TRAMPOLINE COMPONENTS

Trampoline frame	Trampoline bed	Frame padding (where applicable)	Enclosure system
<p>Bending or breakage of frame.</p> <p>Broken, stretched or missing springs.</p> <p>Sharp protrusions on the frame.</p>	<p>Punctures, frays, tears or holes in the bed or edge system.</p> <p>Deterioration in the stitching or fabric of the bed or edge system.</p> <p>Sagging of the bed.</p> <p>Sharp protrusions in the suspension system components.</p>	<p>Missing, improperly positioning or insecurely attached frame padding.</p> <p>Punctures, frays, tears or holes in the frame padding.</p> <p>Deterioration in the stitching or fabric of the frame padding and/or its securing system.</p> <p>Damaged or degraded padding.</p>	<p>Missing, improperly positioning or insecurely attached barrier, barrier supports and/or pole caps.</p> <p>Punctures, frays, tears or holes in the barrier.</p> <p>Damage to the support pole padding (where pole padding is required).</p> <p>Sagging of the barrier.</p> <p>Bent or broken barrier supports.</p> <p>Sharp protrusions on the barrier support structure.</p> <p>Broken or damaged enclosure entry system.</p>

## SAFE USE INFORMATION

Trampolines are great fun, encourage the development of motor skills, provide opportunities for physical activity and present users with manageable challenges to find and test their limits. However, like many physical activities, trampoline use involves potential risk of injury, particularly if the equipment is used improperly.

Injury surveillance and hospital admissions data shows that trampoline features frequently in injury presentations and admissions. Children under 14 years of age accounts for about 90% of all trampoline-related injuries. For children under five years of age, they account for 28% of trampoline-related injuries and more than a third of the injuries are related to multi-users (Victorian Injury Surveillance Unit - Hazard 75, Autumn 2013, Pg 3).

The following points are important to note:

- A. Injury data indicates that people can be severely injured if they land on an unprotected trampoline frame or springs, or if they fall from the trampoline. Impact attenuation systems such as pads are intended to minimise the risk of injury, and enclosures are intended to stop people from falling off the trampoline. Ensure pads (where applicable) and enclosures are attached to the trampoline before use.
- B. The risk of injury increases when more than one person at a time bounces on a trampoline. Smaller children are at increased risk when jumping with adults and/or larger children. For example, a double bounce dramatically increases the energy transferred to the smaller body and children's legs have been broken and severe spinal injuries have occurred as a result. Ensure only one person at a time bounces on the trampoline.
- C. Children are often unable to identify hazards and do not have a well-developed ability to assess risk and may, if left unsupervised, be at more risk of injury. Always supervise children while they are using the trampoline.
- D. Over-confidence can lead to injury. Learn fundamental bounces first before trying more complex manoeuvres.
- E. Inappropriate clothing can cause injury. Clothing should allow plenty of body movement without flapping loosely and becoming a distraction to the jumper. Wear clothing free of drawstrings, hooks, loops or anything that could get caught while using the trampoline and result in entanglement and strangulation. Buckles, jewellery pieces and belts should not be worn, as these may damage the trampoline mat or cause injury to the jumper if they become caught in the fabric of the trampoline. Shoes should be removed as they may damage the bed and increase the risk of injury.

Better design, good construction and improved safety features go a long way toward minimising the hazards associated with trampoline use. However, trampolines need to be used, cared for and maintained appropriately to ensure the benefits of these features continue throughout the life of the product.

## SAFE USE INSTRUCTIONS

To reduce the risk of injury while using the trampoline, develop household rules such as the following:

- A. Do not allow children under 6 years of age on the trampoline.
- B. Allow only one person on the trampoline at any one time.
- C. Always supervise children while they are using the trampoline.
- D. Ensure pads (where applicable) covering the frame/suspension are securely attached at all times.
- E. Ensure the enclosure is securely attached and in good condition at all times.
- F. Check the trampoline before use and ensure that it is in good condition. Replace any worn or broken parts. Use only parts that are recommended by the manufacturer.
- G. Make sure the area around, underneath and above the trampoline is clear of objects that could interfere with the person jumping. Do not allow children, pets, toys or other party equipment be present under the trampoline.
- H. Adults should model safe use of the trampoline when children are present.
- I. Wear comfortable clothing that will not become entangled by components of the trampoline and become a strangulation hazard. Do not wear jewellery pieces or drawstrings/cords that can catch onto the trampoline and create a hazard. Remove shoes when getting on and off the trampoline.
- J. Children should be educated by responsible adults to always climb on and off the trampoline and never jump or bounce off. It is dangerous practice to jump or bounce from the trampoline when dismounting. Never use springs or suspension elements as hand grips when getting on and off the trampoline.
- K. Learn fundamental bounces and body positions thoroughly before trying more advanced manoeuvres. A variety of trampoline activities can be carried out by performing the basic fundamentals in various series and combinations, or performing one fundamental bounce after another, with or without bounces between them.
- L. For further information or additional instruction materials, contact the manufacturer or vendor. To learn more advanced trampolining skills, contact a suitable gymnastics/trampoline club.

## BASIC TRAMPOLINING INSTRUCTIONS

This trampoline is a domestic trampoline, not a gymnastics trampoline. You will get the safest and best use from it by following these basic principles:

- A. Do not attempt or allow somersaults on the trampoline. Landing on your head or neck while doing somersaults can cause serious injury, paralysis or even death.
- B. Do not use the trampoline when wet. The mat will be slippery and make landing less sure.
- C. Enclosure systems are designed to prevent users from falling off the trampoline. Do not allow users to intentionally bounce towards or off the enclosure as this can unbalance the trampoline and continual impact may damage the enclosure.
- D. Do not use a trampoline under the influence of alcohol or drugs. Balance, perception and assessment of risk will be affected and may lead to injury.
- E. Do not use the trampoline as a springboard to other objects. Use the trampoline only for trampoline-style bouncing.
- F. Focus your eyes on the edge of the trampoline. This will help to control your bounce.
- G. Stop your bounce by flexing your knees as your feet come in contact with the trampoline bed. Learn this skill before you attempt others.
- H. Avoid bouncing too high. Stay low until you can control your bounce and repeatedly land in the centre of the trampoline.
- I. Do not bounce immediately after a meal.

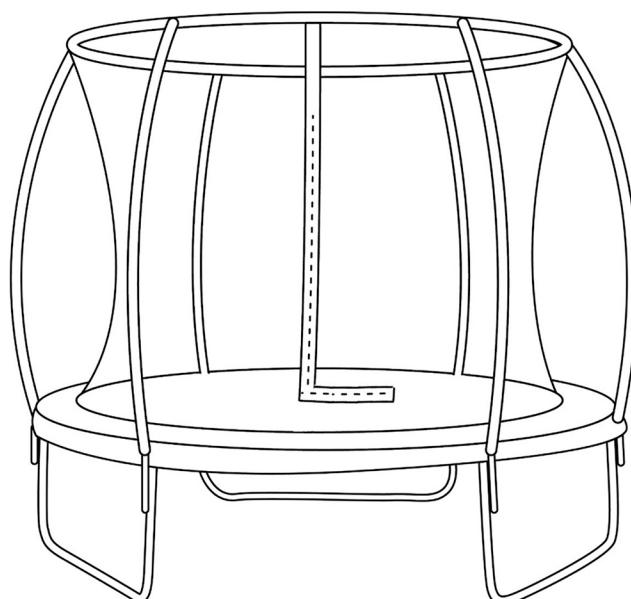

## BASIC TRAMPOLINING SKILLS

These instructions cover basic skills, landing positions, and how to perform a series of landings. The instructions are ordered according to the level of difficulty. These instructions are intended for domestic use and not for gymnastic manoeuvres such as somersaults and flips. Somersaults and flips should not be attempted as they may result in serious injury.

### A. BOUNCING

The most important thing about bouncing is that it should be done with control in the centre of the bed. The basic bounce should always begin low with the jumper always landing with both feet at the same time. High, reckless bouncing should never be allowed.

### B. STOP BOUNCE

This technique allows the jumper to gain control by stopping quickly. It is achieved by keeping the feet in contact with the bed, and absorbing the rebound of the trampoline with the knees and waist. This skill should be the first skill to learn and should be employed whenever you feel out of balance, or land away from the centre area.

To learn the stop bounce:

1. Stand in the centre of the bed with your feet about hip-width apart.
2. Attempt about three easy bounces. Keep them low and controlled.
3. Focus your eyes towards the perimeter of the trampoline while bouncing in order to keep your balance.
4. Stop the bounce by bending at your knees and hips on contact with the bed.
5. Your torso should remain vertical. When stopping the bounce, move your arms either in front of your body or above your head.

### C. ARMS ACTION

Arms are very important for proper control and lift. There are three phases that your arms go through when bouncing:

1. Drive phase: As you make contact with the trampoline, your legs push hard into the trampoline and your arms start to drive up in front of your body.
2. Lift phase: Your arms continue to drive up in front of the body until they are straight above your head.
3. Balance phase: Your hands flair out at the side and slowly come back down while keeping you body balanced and ready to start the process again. See Fig. A.

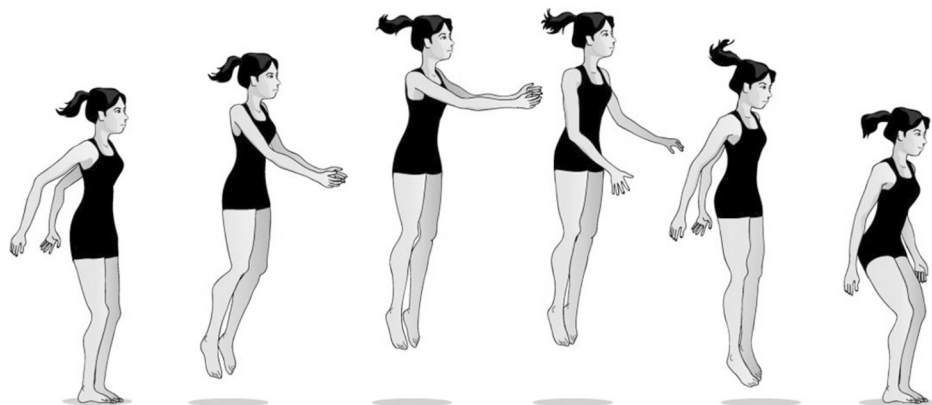

Fig. A: ARMS ACTION

## BASIC TRAMPOLINING SKILLS

### D. BOUNCE VARIATIONS

The three bounce variations are Tuck, Pike and Straddle Pike. These are assumed at the top of the bounce before resuming the normal landing position on your feet. See Fig. B1, B2 and B3.



Fig. B1: TUCK



Fig. B2: PIKE



Fig. B3: STRADDLE PIKE

Practice these simple variations and concentrate on perfect form. Make sure that your toes are pointed and fingers are straight. Maintain good torso posture throughout. These are simple variations to the bounce and are very important for gaining experience in coordinated movements.

# BASIC TRAMPOLINING SKILLS

## E. LANDING POSITIONS

The basic landing positions are as follows.:

1. General landing: This applies to all landings with seat, hands, knees, and front and back. It should be first practiced on the ground in a stationary position and then, onto the trampoline bed. Landings should be performed after 'riding' the trampoline bed, Riding is done by bending your knees and pushing them down repeatedly on the trampoline bed, thereby setting the bed in motion. The feet stay in contact with the bed during the entire riding motion.
2. Seat landing: If you are at or near maximum user weight, you should not attempt this manoeuvre from a height greater than 1.4m above the bed as there is a risk of spinal injury due to contact with the ground.

To learn seat landing:

- i . From the standing position, ride the bed several times.
- ii. Lift up your feet at the top of the last bounce and sit down. You should land so that your body is in a sitting position with legs straight out in front and your toes pointed. Hands should be on the bed slightly behind your hip. Fingers should be together and pointed towards the toes.
- iii. Push on the bed with your hands to rebound up to your feet. See Fig. L1.

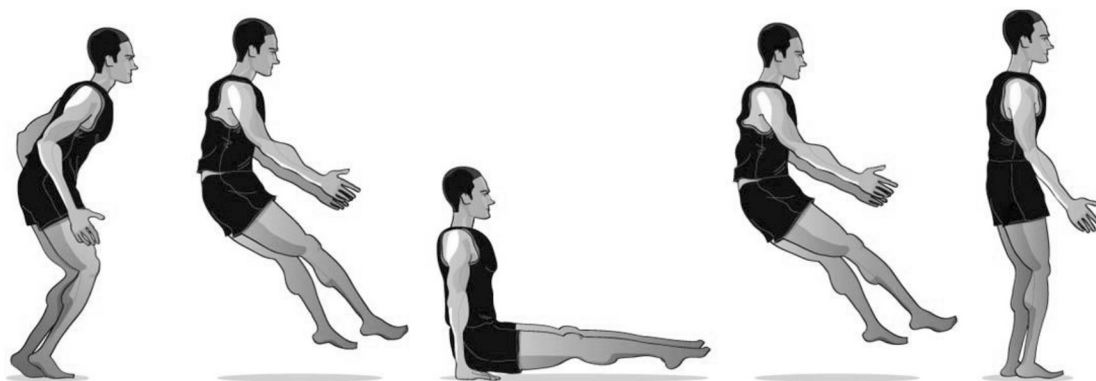

Fig. L1: SEAT LANDING



## BASIC TRAMPOLINING SKILLS

3. Hands and knees landing: To do this landing properly, there should be just as much weight on your hands as on your knees. Your back should be approximately parallel to the bed. Knees and hands should land simultaneously, with the middle of the body landing in the centre of the trampoline. Hands should be directly under the shoulders. Knees should be directly under the hips. Your toes should be pointed.

To learn hands and knees landing:

- i. Get down on your hands and knees on the bed. Make sure you have weight on both your hands and your knees. Do not sit on your heels.
- ii. Remain in this position and try to bounce. Do not rock back and forth between the hands and knees, but develop an even landing on all four points.
- iii. From the standing position, ride the bed several times. Lift upward with your hips, reach forward with your hands, and land on all fours. Look slightly in front of your hands on landing. Push to rebound to your feet. See Fig. L2.

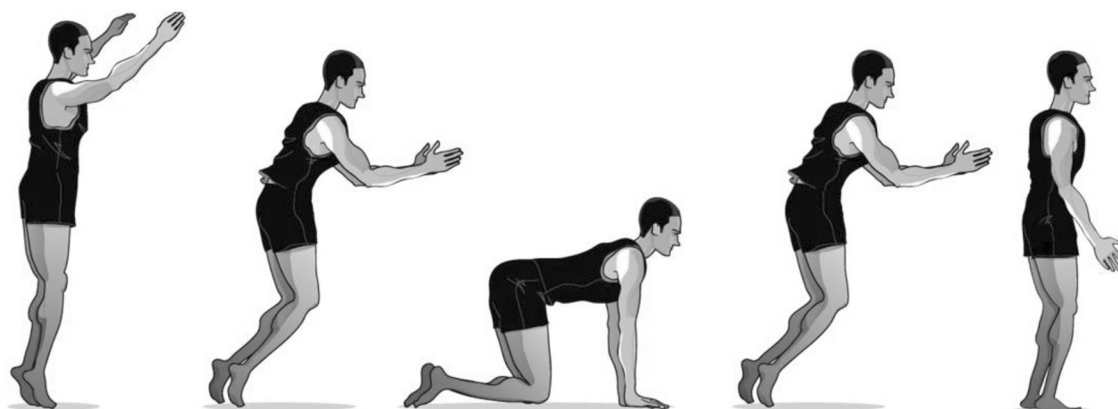

Fig. L2: HANDS AND KNEES LANDING

# INSPECTION CHECKLIST SAMPLE

This sample inspection checklist is for you to ensure that the trampoline is installed and used safely and properly. Any item that is marked 'X' will require adjustment, modification, repairs or maintenance before the trampoline can be safely used.

Date of purchase (Please retain proof of purchase)	✓ or ✗
<b>TRAMPOLINE POSITIONING</b>	
Trampoline is positioned and stable on a level surface.	
Trampoline is positioned on a soft surface (such as well-maintained grass).	
Trampoline is positioned at a minimum distance of 1.5m away from hard surfaces and other potential hazards ( eg, walls, fences, clothes line and trees).	
Adequate clearances are provided above the trampoline ( ≥ 5m).	
Space beneath the trampoline bed is clear of objects (eg bikes, lawn mowers, garden tools and toys).	
<b>TRAMPOLINE FRAME</b>	
Frame is in good condition (eg not bent or broken, no rust or corrosion).	
Legs are secured and locked in position.	
Joints are in good condition (eg no signs of stress, rust or corrosion).	
Frame does not present sharp protrusions or edges.	
<b>TRAMPOLINE SUSPENSION SYSTEM</b>	
Suspension system is in good condition (eg springs are not over-stretched or damaged, and no rust or corrosion is present).	
Suspension system is complete (eg all springs are present and connected).	
Suspension system does not present sharp protrusions or edges.	
<b>TRAMPOLINE BED (JUMPING SURFACE)</b>	
Bed is in good condition (eg no punctures, tears, holes, sagging or other damages).	
Fabric and stitching of the bed is in good condition.	
<b>PADDING (WHERE APPLICABLE)</b>	
Padding is correctly installed and securely attached to exposed poles, edges and springs.	
Padding is in good condition (eg no punctures, tears, holes or other damages).	
Stitching of padding fabric and securing system is in good condition.	
<b>ENCLOSURE</b>	
Enclosure and supports are correctly installed, securely attached and in good condition.	
Pole caps (where applicable) are installed and securely attached.	
Enclosure is in good condition (eg no punctures, tears, holes, sagging or other damages).	
Stitching of the enclosure is in good condition.	
Enclosure support structure does not present sharp protrusions.	
Enclosure entrance is in good condition and not broken or damaged.	